

# Chapter 7

## Digital Representation of Analog Signals



Wireless Information Transmission System Lab.  
Institute of Communications Engineering  
National Sun Yat-sen University

# Contents



- ◇ 7.1 Introduction
- ◇ 7.2 Why Digitize Analog Sources ?
- ◇ 7.3 The Sampling Process
- ◇ 7.4 Pulse-Amplitude Modulation
- ◇ 7.5 Time-Division Modulation
- ◇ 7.6 Pulse-Position Modulation
- ◇ 7.8 The Quantization Process
- ◇ 7.9 Pulse-Code Modulation
- ◇ 7.10 Delta Modulation

# Chapter 7.1

## Introduction



Wireless Information Transmission System Lab.  
Institute of Communications Engineering  
National Sun Yat-sen University

# 7.1 Introduction



- ◇ In the first step from analog to digital, an analog source is sampled at discrete times. The resulting analog samples are then transmitted by means of analog pulse modulation.
  - ◇ Pulse-Amplitude Modulation (PAM), the simplest form of analog pulse modulation.
  - ◇ Pulse-Position Modulation (PPM)
  
- ◇ In the second step from analog to digital, an analog source is not only sampled at discrete times but the samples themselves are also quantized to discrete levels.
  - ◇ Pulse-code Modulation (PCM)
  - ◇ Delta Modulation (DM)

# Chapter 7.2

## Why Digitize Analog Source ?



Wireless Information Transmission System Lab.  
Institute of Communications Engineering  
National Sun Yat-sen University

# 7.2 Why Digitize Analog Source ?



- ◇ Advantages of digital transmission over analog transmission:
  - ◇ Digital systems are less sensitive to noise than analog. For long transmission lengths, the signal may be regenerated effectively error-free at different point along the path and the original signal transmitted over the remaining length.
  - ◇ With digital systems, it is easier to integrate different services, for example, video and the accompanying soundtrack, into the same transmission scheme.
  - ◇ The transmission scheme can be relatively independent of the source. For example, a digital transmission scheme that transmits voice at 10 kbps could also be used to transmit computer data at 10 kbps.
  - ◇ Circuitry for handling digital signals is easier to repeat and digital circuits are less sensitive to physical effect such as vibration and temperature.
  - ◇ Digital signals are simpler to characterize and typically do not have the same amplitude range and variability as analog signals. This makes the associated hardware easier to design.

# 7.2 Why Digitize Analog Source ?



- ◇ Digital techniques offer strategies for more efficient use of media, e.g. cable, radio wave, and optical fibers.
  - ◇ Various media sharing strategies, known as multiplexing techniques, are more easily implemented with digital transmission strategies.
  - ◇ There are techniques for removing redundancy from a digital transmission, so as to minimize the amount of information that has to be transmitted. These techniques fall under the broad classification of source coding and we discuss some of these techniques in Chapter 10.
  - ◇ There are techniques for adding controlled redundancy to digital transmission, such that errors occur during transmission may be corrected at the receiver without any additional information. These techniques fall under the general category of channel coding, which is described in Chapter 10.

# 7.2 Why Digitize Analog Source ?



- ◇ Digital techniques make it easier to specify complex standards that may be shared on a worldwide basis. This allows the development of communication components with many different features (e.g., a cellular handset) and their interoperation with a different component (e.g., a base station) produced by a different manufacturer.
- ◇ Other channel compensations techniques, such as equalization, especially adaptive versions, are easier to implement with digital transmission techniques.
- ◇ It should be emphasized that the majority of these advantages for digital transmission rely on availability of low-cost microelectronics.



# Chapter 7.3

## The Sampling Process

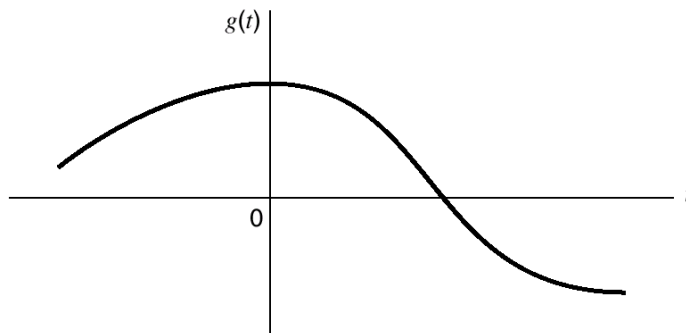


Wireless Information Transmission System Lab.  
Institute of Communications Engineering  
National Sun Yat-sen University

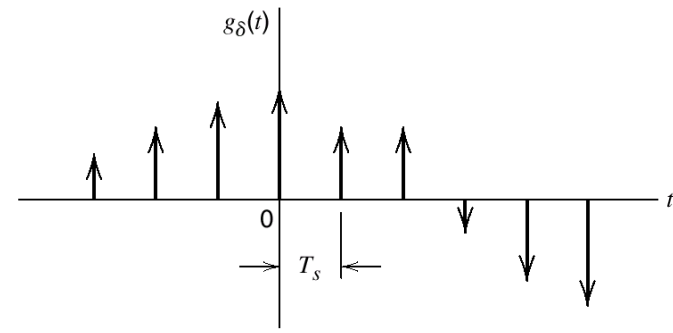
# 7.3 The Sampling Process



- ◇ Through use of the sampling process, an analog signal is converted into a corresponding sequence of samples that are usually spaced uniformly in time.
- ◇ It is necessary that we choose the sampling rate properly, so that the sequence of samples uniquely defines the original analog signal.
- ◇ Let  $g_\delta(t)$  denote the ideal sampled signal
$$g_\delta(t) = g(t) \cdot \left[ \sum_{n=-\infty}^{\infty} \delta(t - nT_s) \right] = \sum_{n=-\infty}^{\infty} g(nT_s) \delta(t - nT_s) \quad (7.1)$$
- ◇ We refer to  $T_s$  as the sampling period,  $f_s = 1/T_s$  as the sampling rate.



(a)



(b)

# 7.3 The Sampling Process



- ◇ Applying Eq. (2.88), we get the result

$$g_{\delta}(t) \rightleftharpoons f_s \sum_{m=-\infty}^{\infty} G(f - mf_s)$$

$$\sum_{m=-\infty}^{\infty} g(t - mT_0) \rightleftharpoons f_0 \sum_{n=-\infty}^{\infty} G(nf_0) \delta(f - nf_0) \quad (2.88)$$

$$\sum_{m=-\infty}^{\infty} \delta(t - mT_0) \rightleftharpoons f_0 \sum_{n=-\infty}^{\infty} \delta(f - nf_0) \quad (2.89)$$

$$(7.2)$$

where  $G(f)$  is the Fourier transform of the original signal  $g(t)$  and  $f_s$  is the sampling rate.

- ◇ Eq. (7.2) state that the process of uniformly sampling a continuous-times signal of finite energy results in a periodic spectrum with a period equal to the sampling rate.

- ◇ Taking the (discrete-time) Fourier transform of both sides of Eq. (7.1), we get

$$\delta(t - nT_s) \rightleftharpoons \exp(-j2\pi fnT_s)$$

$$G_{\delta}(f) = \sum_{n=-\infty}^{\infty} g(nT_s) \exp(-j2\pi fnT_s) \quad (7.3)$$

# 7.3 The Sampling Process



◇ Hence, under the following two conditions

1.  $G(f) = 0$  for  $|f| \geq W$  (Band-Limited Signal)

2.  $f_s = 2W$  (or  $T_s = \frac{1}{2W}$ )

we can get (from Eq. (7.3))

$$G_\delta(f) = \sum_{n=-\infty}^{\infty} g\left(\frac{n}{2W}\right) \exp\left(-\frac{j\pi n f}{W}\right) \quad (7.4)$$

◇ From Eq. (7.2), we readily see that the Fourier transform of  $g_\delta(t)$  may also be expressed as

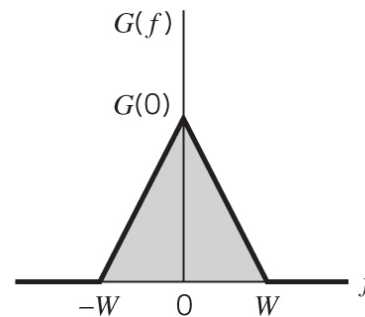
$$G_\delta(f) = f_s G(f) + f_s \sum_{\substack{m=-\infty \\ m \neq 0}}^{\infty} G(f - mf_s) \quad (7.5)$$

# 7.3 The Sampling Process

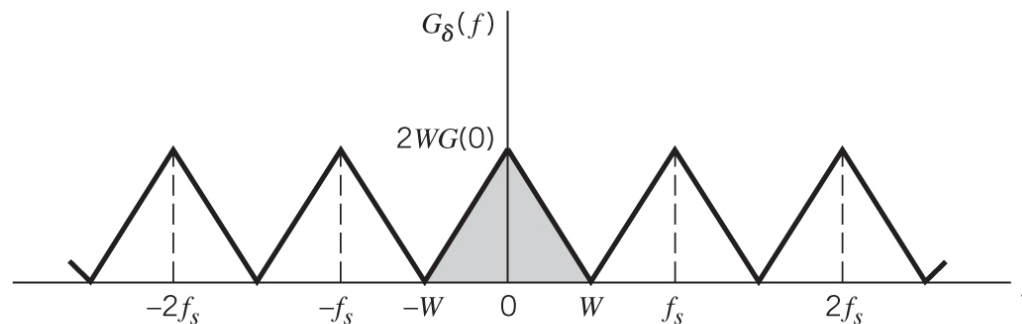


◇ We find from Eq. (7.5) that

$$G(f) = \frac{1}{2W} G_{\delta}(f), \quad -W < f < W \quad (7.6)$$



(a)



(b)

## 7.3 The Sampling Process



- ◇ Substituting Eq. (7.4) in Eq. (7.6), we may also write

$$G(f) = \frac{1}{2W} \sum_{n=-\infty}^{\infty} g\left(\frac{n}{2W}\right) \exp\left(-\frac{j\pi n f}{W}\right), \quad -W < f < W \quad (7.7)$$

(Physical meaning?)

- ◇ Therefore, if the sample values of a signal  $g(t)$  are specified for all time, then the Fourier transform  $G(f)$  of the signal is uniquely determined by using the discrete-time Fourier transform of Eq. (7.7) .
- ◇ In the other words, the sequence  $\{g(n/2W)\}$  has all the information contained in  $g(t)$ .

# 7.3 The Sampling Process



## ◇ Reconstructing the signal of $g(t)$

- ◇ Substituting Eq. (7.7) in the formula for the inverse Fourier transform  $g(t)$  in terms of  $G(f)$ , we get

$$\begin{aligned} g(t) &= \int_{-\infty}^{\infty} G(f) \exp(j2\pi ft) df \\ &= \int_{-W}^W \frac{1}{2W} \sum_{n=-\infty}^{\infty} g\left(\frac{n}{2W}\right) \exp\left(-\frac{j\pi nf}{W}\right) \exp(j2\pi ft) df \end{aligned}$$

- ◇ Interchanging the order of summation and integration

$$g(t) = \sum_{n=-\infty}^{\infty} g\left(\frac{n}{2W}\right) \frac{1}{2W} \int_{-W}^W \exp\left[j2\pi f\left(t - \frac{n}{2W}\right)\right] df \quad (7.8)$$

$$g(t) = \sum_{n=-\infty}^{\infty} g\left(\frac{n}{2W}\right) \frac{\sin(2\pi Wt - n\pi)}{(2\pi Wt - n\pi)} = \sum_{n=-\infty}^{\infty} g\left(\frac{n}{2W}\right) \text{sinc}(2Wt - n) \quad -\infty < t < \infty \quad (7.9)$$

# 7.3 The Sampling Process



- ◇ **Reconstructing the signal of  $g(t)$** 
  - ◇ Eq. (7.9) provides an interpolation formula for reconstructing the original signal from the sequence of sample values  $\{g(n/2W)\}$ , with the  $\text{sinc}(2Wt)$  playing the role of an interpolation function.
  - ◇ Eq. (7.9) can be looked in another way: it represents the convolution (or filtering) of the impulse train  $g_\delta(t)$  given by Eq. (7.1) with the impulse response  $\text{sinc}(2Wt)$ .
  - ◇ Any impulse response that plays the same roles as  $\text{sinc}(2Wt)$  is also referred to as a reconstruction filter.



# 7.3 The Sampling Process

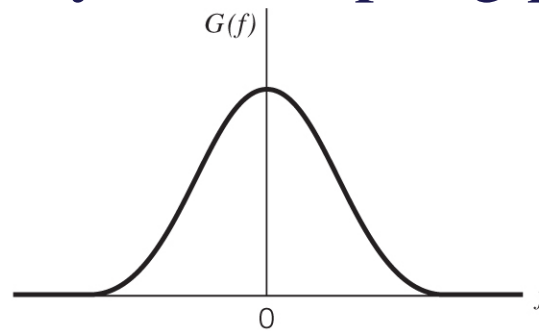


- ◇ The sampling theorem for strictly band-limited signals of finite energy may be stated in two equivalent parts
  - ◇ A band-limited signal of finite energy, which only has frequency components less than  $W$  Hz, is completely described by specifying the values of the signal at instants of time separated by  $1/2W$  seconds. (Transmitter Side)
  - ◇ A band-limited signal of finite energy, which only has frequency components less than  $W$  Hz, may be completely recovered from a knowledge of its samples taken at the rate of  $2W$  samples per second. (Receiver Side)
- ◇ The sampling rate of  $2W$  samples per second, for a signal bandwidth of  $W$  Hz, is called the Nyquist rate; its reciprocal  $1/2W$  (measured in seconds) is called Nyquist interval.

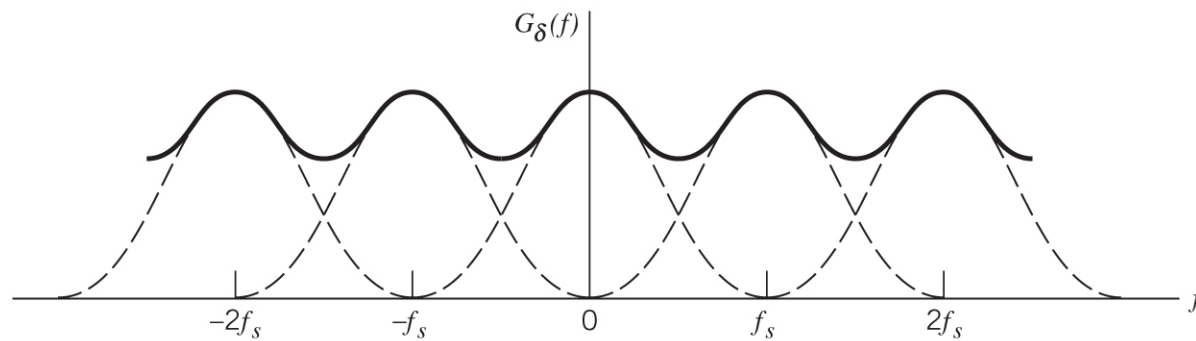
# 7.3 The Sampling Process



- ◇ In practice, however, an information-bearing signal is **not strictly band-limited**, with the result that some degree of undersampling is encountered. Consequently, some aliasing is produced by the sampling process.



(a)



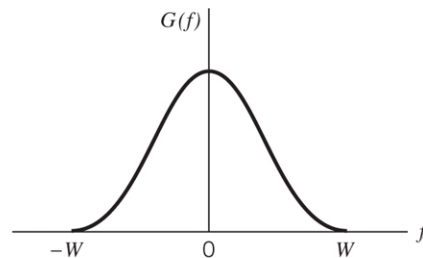
(b)

# 7.3 The Sampling Process

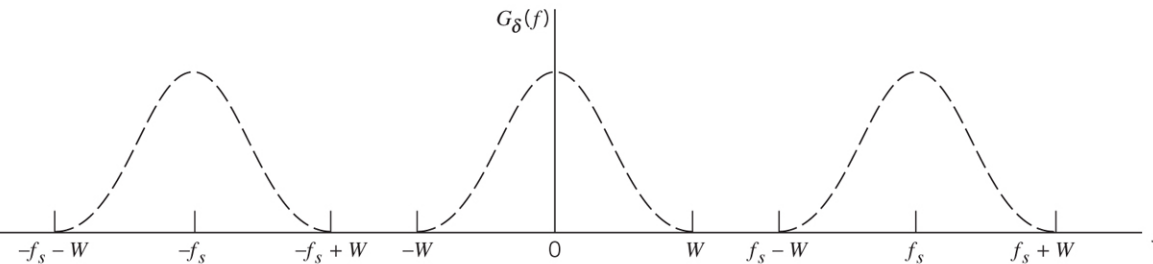


- ◇ To combat the effects of aliasing in practice, we may use two corrective measures, as described here
  - ◇ Prior to sampling, a low-pass pre-alias filter is used to attenuate those high-frequency components of the signal that are not essential to the information being conveyed by the signal.
  - ◇ The filtered signal is sampled at a rate slightly higher than the Nyquist rate.
- ◇ The use of a sampling rate higher than Nyquist rate also has beneficial effect of easing the design of the reconstruction filter used to recover the original signal from its sampled version.

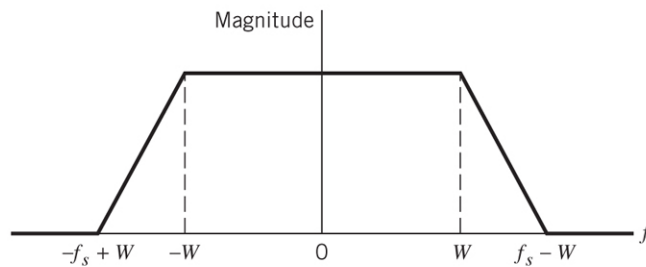
# 7.3 The Sampling Process



(a)



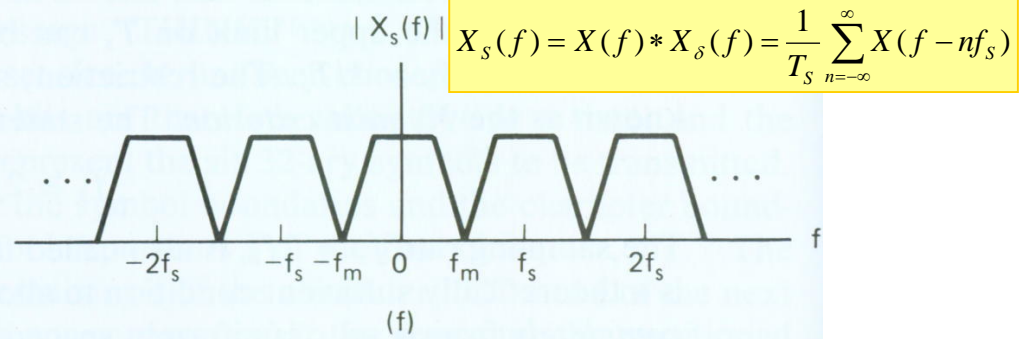
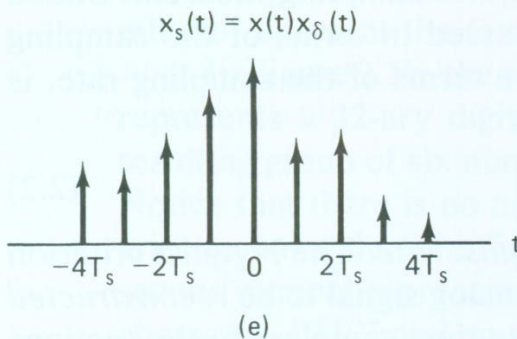
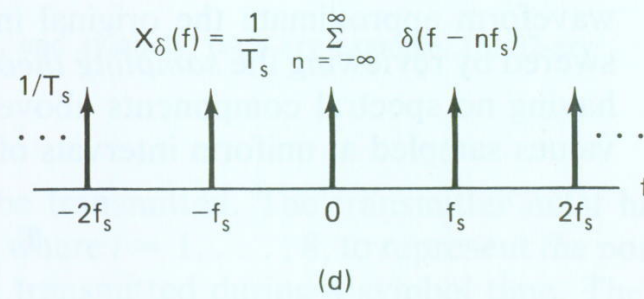
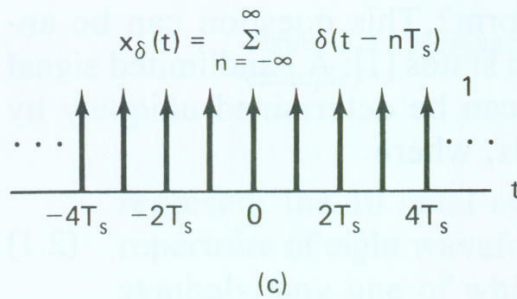
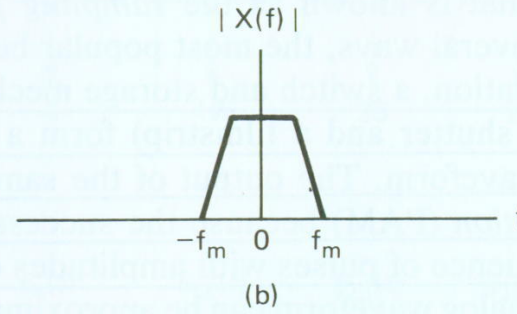
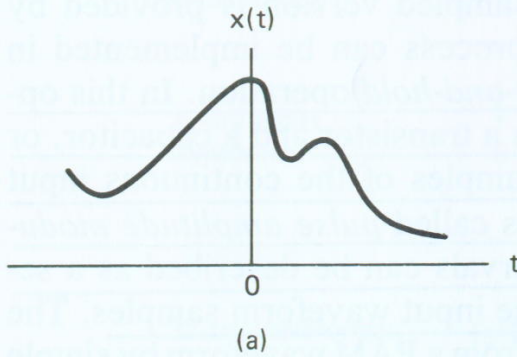
(b)



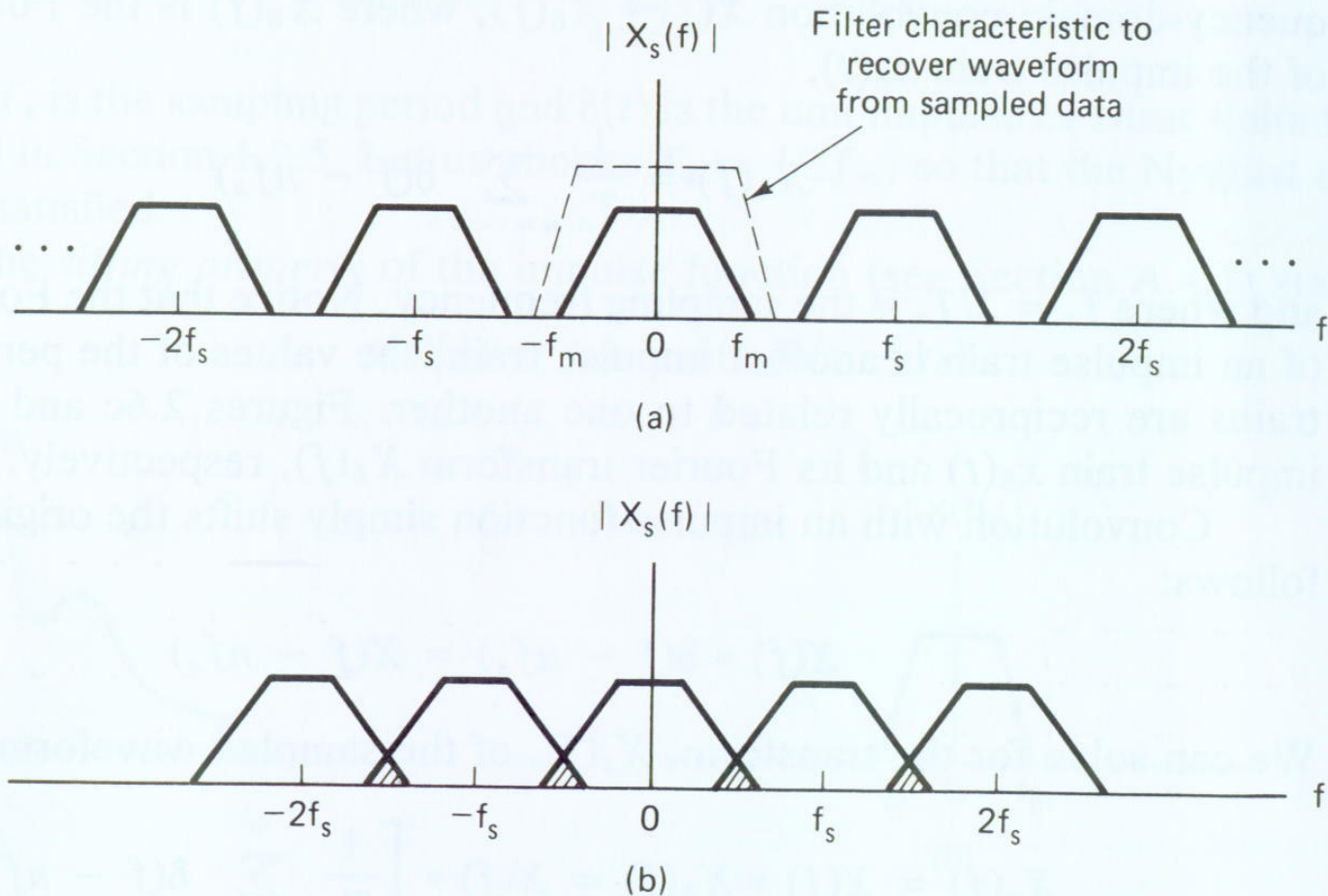
(c)

- ◇ The reconstruction filter is low-pass with a passband extending from  $-W$  to  $W$ .
- ◇ The reconstruction filter has a transition band extending from  $W$  to  $f_s - W$ .
- ◇ The fact that the reconstruction filter has a well defined transition band means that it is physically realizable.

# Nyquist Sampling Theorem

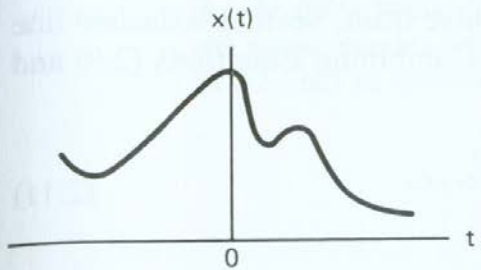


# Spectra for Various Sampling Rates

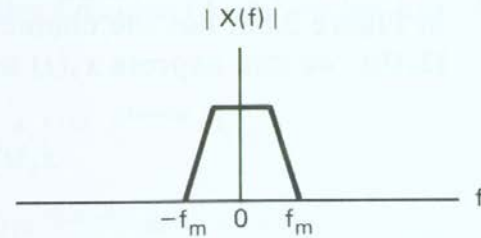


**Figure 2.7** Spectra for various sampling rates. (a) Sampled spectrum ( $f_s > 2f_m$ ). (b) Sampled spectrum ( $f_s < 2f_m$ ).

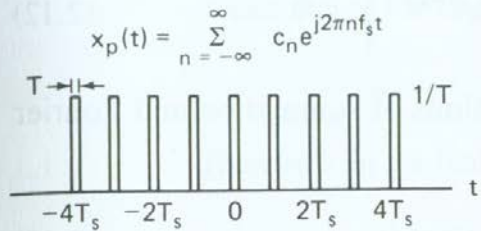
# Natural Sampling



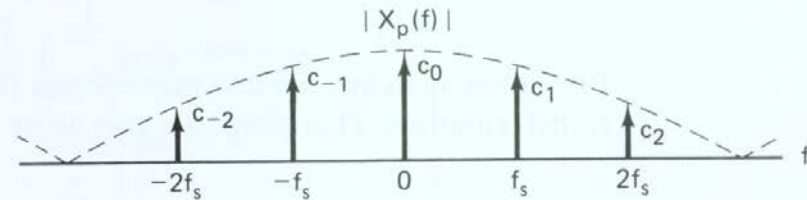
(a)



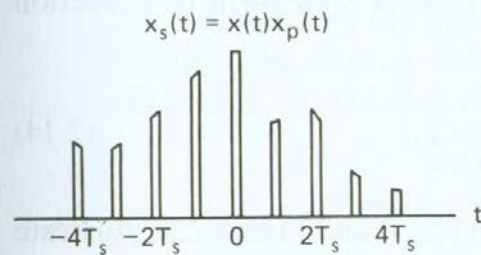
(b)



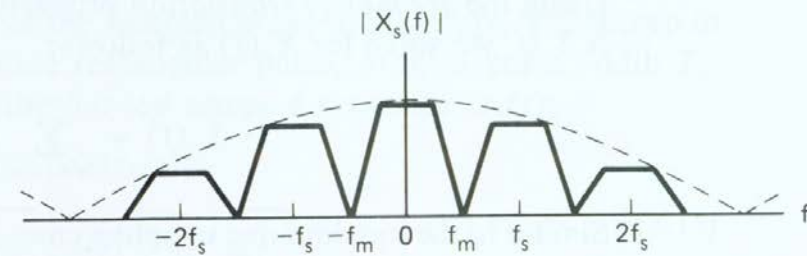
(c)



(d)



(e)



(f)

**Figure 2.8** Sampling theorem using the frequency shifting property of the Fourier transform.



# Chapter 7.4

## Pulse-Amplitude Modulation



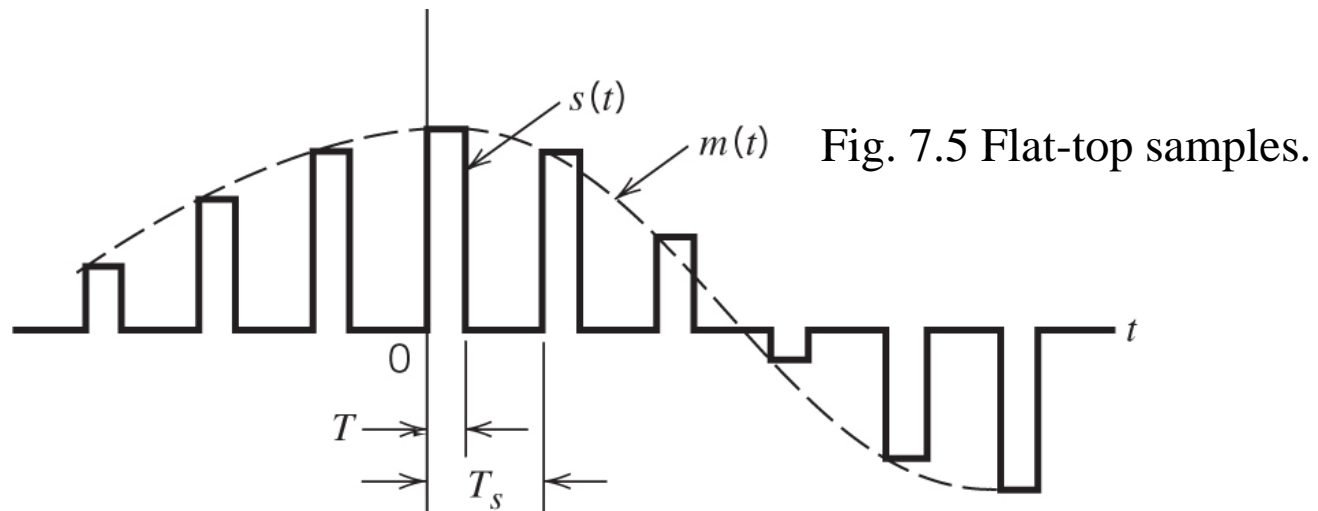
Wireless Information Transmission System Lab.  
Institute of Communications Engineering  
National Sun Yat-sen University



# 7.4 Pulse-Amplitude Modulation



- ◇ In pulse-amplitude modulation (PAM), the amplitudes of regularly spaced pulses are varied in proportion to the corresponding sample values of a continuous message signal; the pulses can be of a rectangular form or some other shape.
- ◇ PAM is somewhat similar to natural sampling, where the message signal is multiplied by a periodic train of rectangular pulses.
- ◇ In natural sampling the top of each modulated rectangular pulse varies with the message signal. In PAM it is maintained flat.



# 7.4 Pulse-Amplitude Modulation



- ◇ Two operations are involved in the generation of the PAM signal
  - ◇ Instantaneous sampling of the message signal  $m(t)$  every  $T_s$  seconds, where the sampling rate  $f_s = 1/T_s$  is chosen in accordance with the sampling theorem.
  - ◇ Lengthening the duration of each sample so obtained to some constant value  $T$ .
  
- ◇ In digital circuit technology, these two operations are jointly referred to as “sample and hold.”
  
- ◇ One important reason for intentionally lengthening the duration of each sample is to avoid the use of an excessive channel bandwidth, since bandwidth is inversely proportional to pulse duration.

# Chapter 7.5

## Time-Division Multiplexing



Wireless Information Transmission System Lab.  
Institute of Communications Engineering  
National Sun Yat-sen University

# 7.5 Time-Division Multiplexing

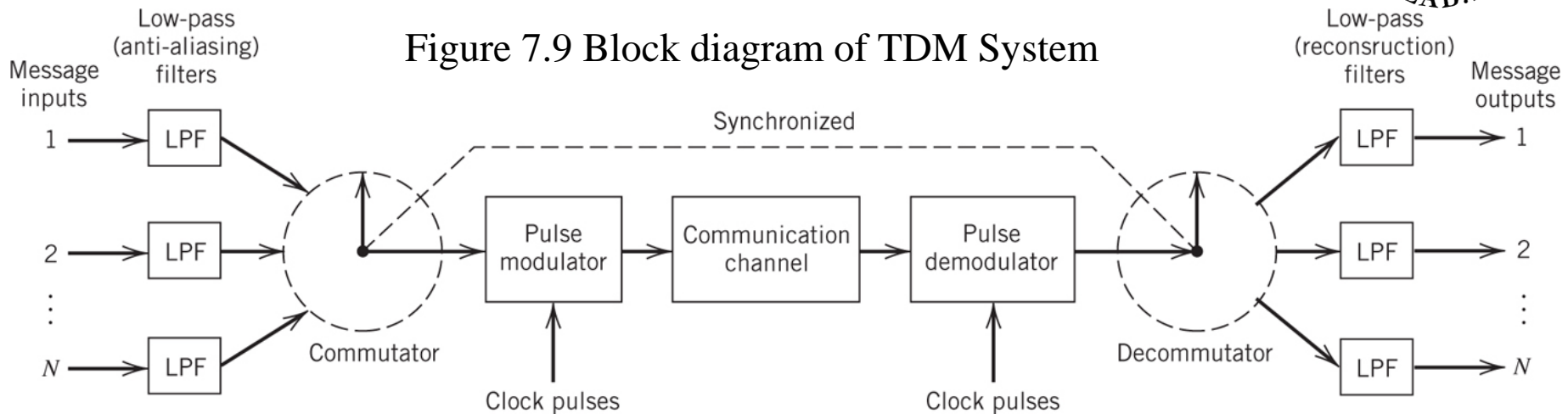


- ◇ The sampling theorem provides the basis for transmitting the information contained in a band-limited message signal  $m(t)$  as a sequence of samples of  $m(t)$  taken uniformly at a rate that is slightly higher than the Nyquist rate.
- ◇ An important feature of the sampling process is a conservation of time. That is, the transmission of the message samples engages the communication channel for only a fraction of the sampling interval on a periodic basis, and in this way some of the time interval between adjacent samples is cleared for use by other independent message sources on a time-shared basis.
- ◇ We thereby obtain a *time-division multiplex* (TDM) system, which enables the joint utilization of a common communication channel by a plurality of independent message sources without mutual interference among them.

# 7.5 Time-Division Multiplexing



Figure 7.9 Block diagram of TDM System



◇ Low-pass pre-alias filter:

- ◇ To remove the frequencies that are nonessential to an adequate signal representation.

◇ Commutator:

- ◇ To take a narrow sample of each of the  $N$  input messages at a rate  $f_s$  that is slightly higher than  $2W$ , where  $W$  is the cut-off frequency of the pre-alias filter.
- ◇ To sequentially interleave these  $N$  samples inside the sampling interval  $T_s$ .

# 7.5 Time-Division Multiplexing



## ◇ Pulse modulator:

- ◇ To transform the multiplexed signal into a form suitable for transmission over the common channel.
- ◇ The use of TDM introduces a bandwidth expansion factor  $N$ , because the scheme must squeeze  $N$  samples derived from  $N$  independent message sources into a time slot equal to one sampling interval.

## ◇ Pulse demodulator :

- ◇ Performs the reverse operation of the pulse modulator.

## ◇ Decommutator:

- ◇ The narrow samples produced at the pulse demodulator output are distributed to the appropriate low-pass reconstruction filters.
- ◇ In synchronism with commutator in the transmitter.

# Chapter 7.6

## Pulse-Position Modulation



Wireless Information Transmission System Lab.  
Institute of Communications Engineering  
National Sun Yat-sen University

# 7.6 Pulse-Position Modulation



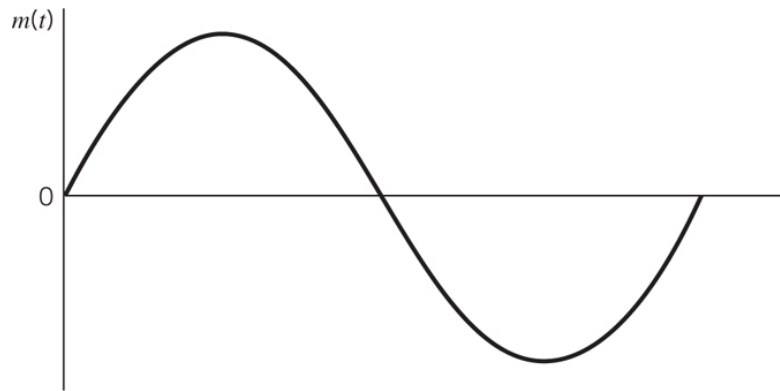
- ◇ In a pulse modulation system, we may use the increased bandwidth consumed by pulses to obtain an improvement in noise performance by representing the sample values of the message signal by some property of the pulse other than amplitude.
- ◇ Pulse-Duration Modulation (PDM): the samples of the message signal are used to vary the duration of the individual pulses. This form of modulation is also referred to as Pulse-Width Modulation (PWM) or Pulse-Length Modulation (PLM).
  - ◇ In PDM, long pulses expend considerable power during the pulse while bearing no addition information.
- ◇ Pulse-Position Modulation (PPM): the position of a pulse relative to its unmodulated time of occurrence is varied in accordance with the message signal.



# 7.6 Pulse-Position Modulation



Modulating Wave



(a)

Pulse Carrier



(b)

PDM Signal



(c)

PPM Signal



Time →

(d)

# 7.6 Pulse-Position Modulation



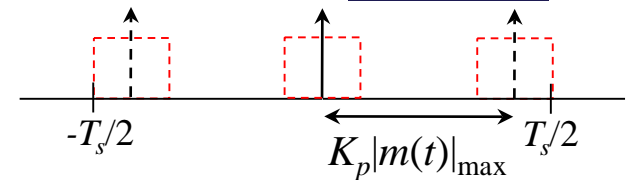
## Mathematical Representation of PPM Signal

- Using the sample  $m(nT_s)$  of a message signal  $m(t)$  to modulate the position of the  $n$ th pulse, we obtain the PPM signal

$$s(t) = \sum_{n=-\infty}^{\infty} g(t - nT_s - k_p m(nT_s)) \quad (7.20)$$

where  $k_p$  is the sensitivity of the pulse-position modulator and  $g(t)$  denotes a standard pulse of interest.

- The different pulses constituting the PPM signal  $s(t)$  must be strictly non-overlapping.



- A sufficient condition is given by:

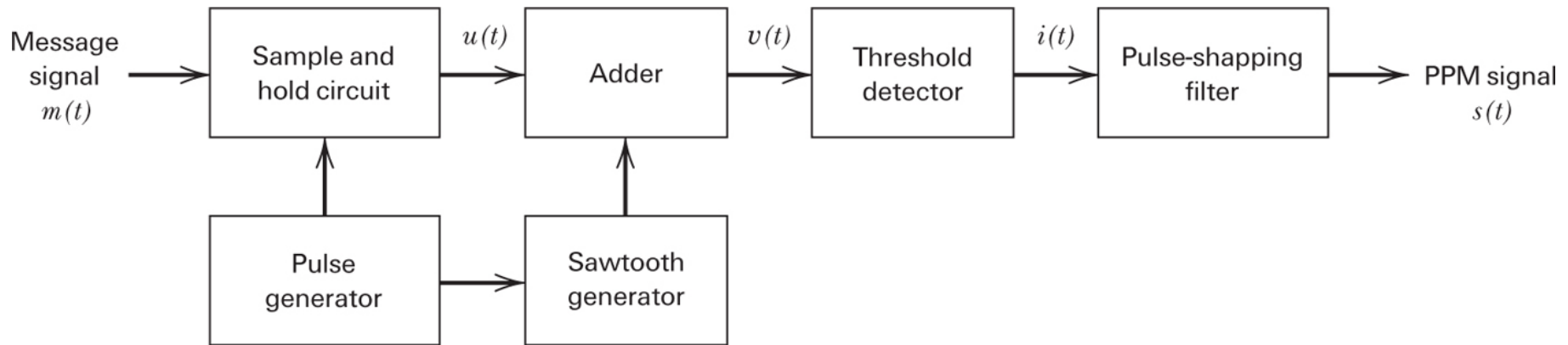
$$g(t) = 0, \quad |t| > \frac{T_s}{2} - k_p |m(t)|_{\max} \quad (7.21)$$

which in turn requires  $k_p |m(t)|_{\max} < \frac{T_s}{2}$  (7.22)

# 7.6 Pulse-Position Modulation



## ◇ Generation of PPM waves

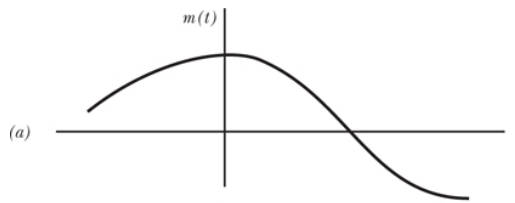


- ◇ The message signal  $m(t)$  is first converted in to a PAM signal by means of a sample-and-hold circuit, generating a staircase waveform  $u(t)$ .
- ◇ Next, the signal  $u(t)$  is added to a sawtooth wave, yielding the combined signal  $v(t)$ .

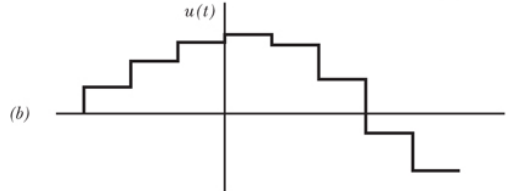
# 7.6 Pulse-Position Modulation



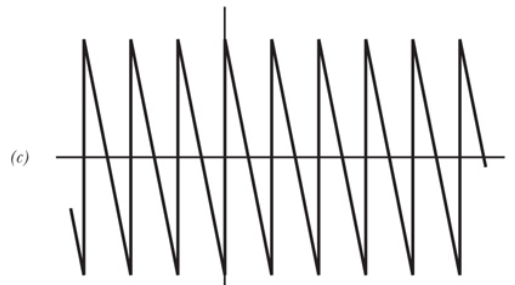
(a) Message signal



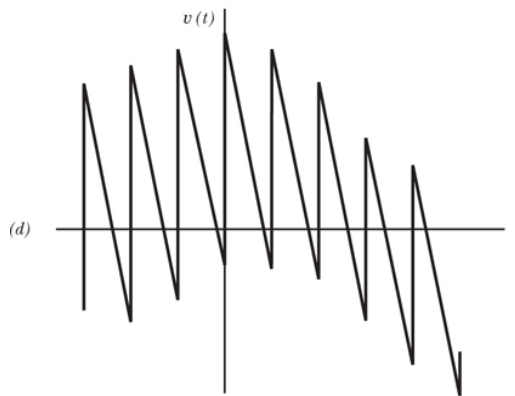
(b) Staircase approximation of the message signal



(c) Sawtooth wave



(d) Composite wave



(e) Sequence of Impulses used to generate the PPM signal



- ◇ The  $v(t)$  is applied to a threshold detector that produces a very narrow pulse (approximating an impulse) each time  $v(t)$  crosses zero in the negative-going direction.
- ◇ Finally, the PPM signal  $s(t)$  is generated by using this sequence of impulses to excite a filter whose impulse response is defined by the standard pulse  $g(t)$ .

# Chapter 7.8

## The Quantization Process



Wireless Information Transmission System Lab.  
Institute of Communications Engineering  
National Sun Yat-sen University

# 7.8 The Quantization Process

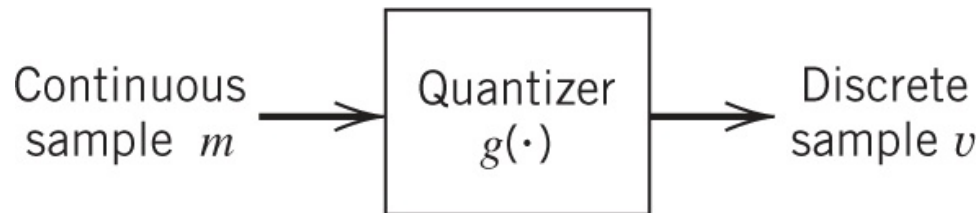


- ◇ A continuous signal has infinite number of amplitude levels.
- ◇ It is not necessary in fact to transmit the exact amplitudes of the samples.
- ◇ Any human sense can detect only finite intensity differences.
- ◇ The original continuous signal may be approximated by a signal constructed of discrete amplitudes selected on a minimum error basis from an available set.
- ◇ Amplitude quantization is defined as the processes of transforming the sample amplitude  $m(nT_s)$  of message signal  $m(t)$  at time  $t = nT_s$  into a discrete amplitude  $v(nT_s)$  taken from a finite set of possible amplitudes.
- ◇ We assume that the quantization process is memoryless and instantaneous.

# 7.8 The Quantization Process

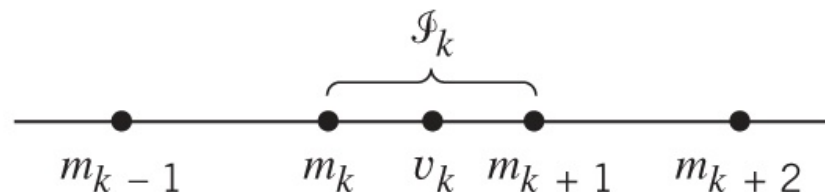


- ◇ Since we are dealing with a memoryless quantizer, we may use the symbol  $m$  in place of  $m(nT_s)$ .



- ◇ The signal amplitude  $m$  is specified by the index  $k$  if it lies inside the interval, where  $L$  is the total number of amplitude levels used in the quantizer.

$$\mathcal{I}_k : \{m_k < m \leq m_{k+1}\}, \quad k = 1, 2, \dots, L \quad (7.32)$$



# 7.8 The Quantization Process



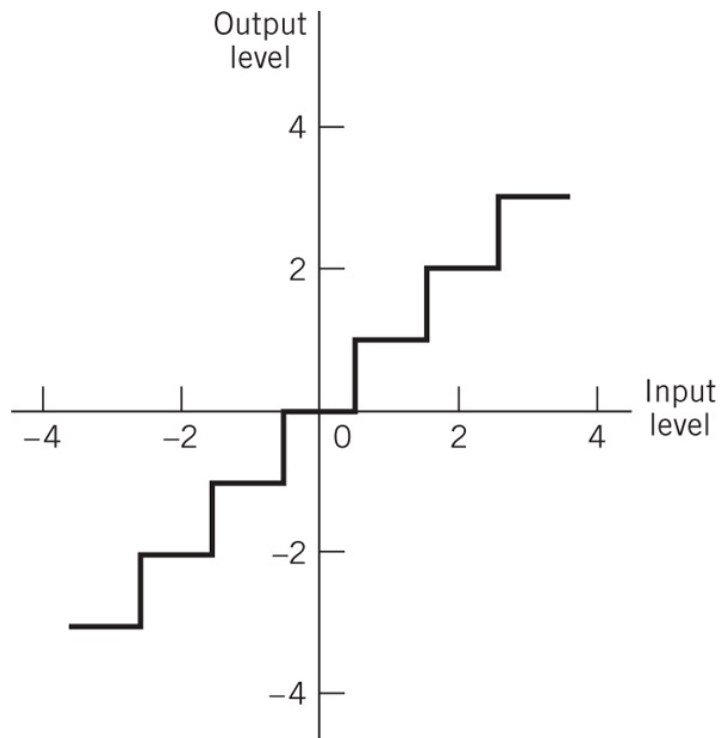
- ◇ The  $m_k$  are called decision levels or decision thresholds.
- ◇ The  $v_k$  are called representation levels or reconstruction levels.
- ◇ The spacing between two adjacent representation levels is called a quantum or step-size.
- ◇ The mapping  $v=g(m)$  is the quantizer characteristic, which is a staircase function by definition.
- ◇ Quantizers can be uniform or nonuniform.
  - ◇ In a uniform quantizer, the representation levels are uniformly spaced, otherwise, the quantizer is non-uniform.
- ◇ The quantizer characteristic can be of midtread or midrise type.



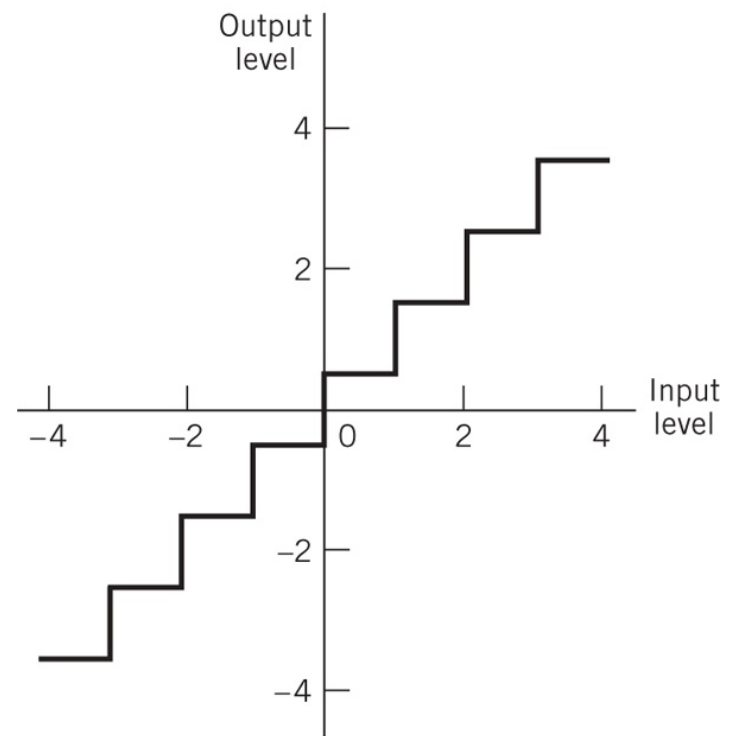
# 7.8 The Quantization Process



Midtread type



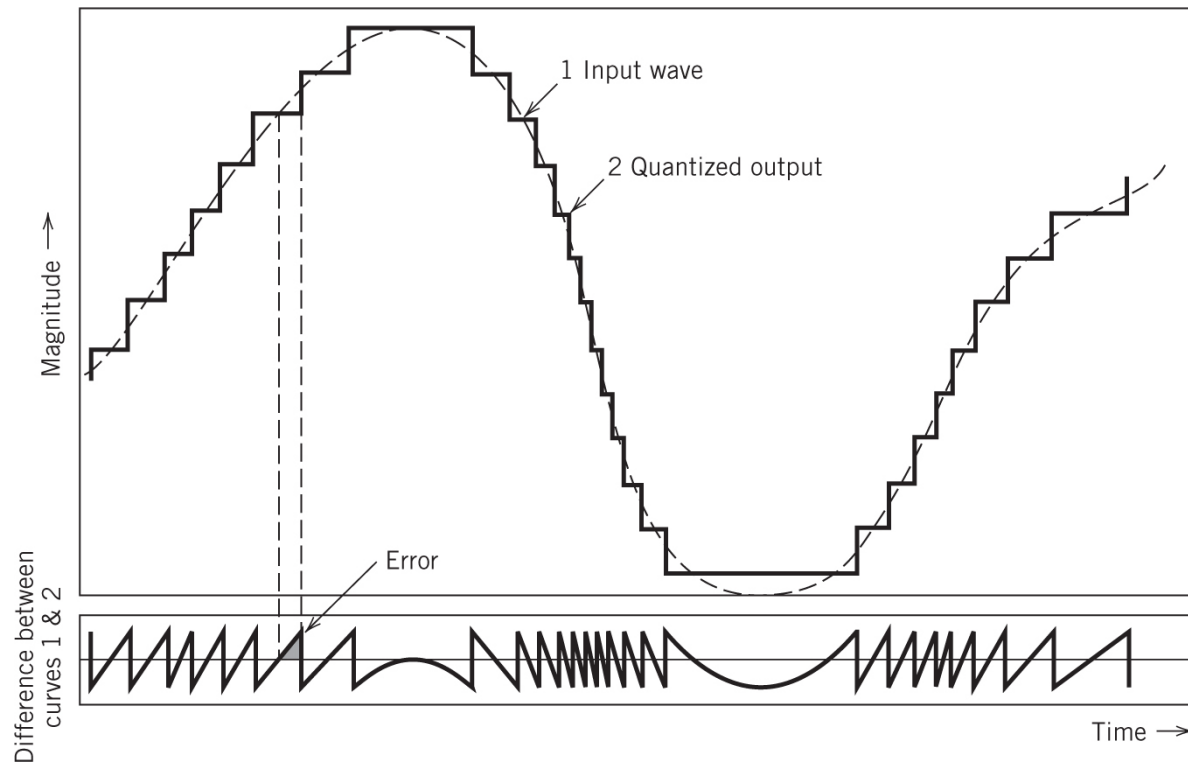
Midrise type



# 7.8 The Quantization Process



- ◇ Quantization Noise
  - ◇ The use of quantization introduces an error defined as the difference between the input signal  $m$  and the output signal  $v$ .
  - ◇ This error is called quantization noise.



# 7.8 The Quantization Process



- ◇ For simplicity, let the quantizer input  $m$  be the sample value of a zero-mean random variable  $M$ .
- ◇ A quantizer  $g(\cdot)$  maps the input random variable  $M$  of continuous amplitude into a discrete random variable  $V$ .
- ◇ Let the quantization error be denoted by the random variable  $Q$  of sample value  $q$ . We may thus write

$$q = m - v \quad (7.34)$$

or

$$Q = M - V \quad (7.35)$$

- ◇ With the input  $M$  having zero mean, and the quantizer assumed to be symmetric, it follows that the quantizer output  $V$  and therefore the quantization error  $Q$  will also have zero mean.
- ◇ In order to find the output signal-to-noise ratio, we need to find the mean-square value of the quantization error  $Q$ .

# 7.8 The Quantization Process



- ◇ Consider an input  $m$  of continuous amplitude in the range  $(-m_{\max}, m_{\max})$ . Assuming a uniform quantizer of the midrise type, we find the step-size of the quantizer is given by

$$\Delta = \frac{2m_{\max}}{L} \quad (7.36)$$

where  $L$  is the total number of representation levels.

- ◇ For a uniform quantizer, the quantization error  $Q$  will have its sample values bounded by  $-\Delta/2 \leq q \leq \Delta/2$ .
- ◇ If  $\Delta$  is sufficiently small or  $L$  is sufficiently large, it is reasonable to assume that the quantization error  $Q$  is a uniform distributed random variable. The probability density function of the quantization error  $Q$  is

$$f_Q(q) = \begin{cases} \frac{1}{\Delta}, & -\frac{\Delta}{2} < q \leq \frac{\Delta}{2} \\ 0, & \text{otherwise} \end{cases} \quad (7.37)$$

# 7.8 The Quantization Process



- ◇ Its variance is

$$\sigma_Q^2 = \int_{-\Delta/2}^{\Delta/2} q^2 f_Q(q) dq = \mathbf{E}[Q^2] \quad (7.38)$$

- ◇ Substituting Eq. (7.37) in (7.38), we get

$$\sigma_Q^2 = \frac{1}{\Delta} \int_{-\Delta/2}^{\Delta/2} q^2 dq = \frac{\Delta^2}{12} \quad (7.39)$$

- ◇ Typically, the  $L$ -ary number  $k$ , denoting the  $k$ th representation level of the quantizer, is transmitted to the receiver in binary form.
- ◇ Let  $R$  denote the number of bits per sample used in the construction of the binary code.

$$L = 2^R \quad (7.40)$$

$$R = \log_2 L \quad (7.41)$$

# 7.8 The Quantization Process



- ◇ Substituting Eq. (7.40) in (7.36)

$$\Delta = \frac{2m_{\max}}{L} = \frac{2m_{\max}}{2^R} \quad (7.42)$$

- ◇ Thus, the use of Eq. (7.42) in (7.39) yields

$$\sigma_Q^2 = \frac{\Delta^2}{12} = \frac{1}{3} m_{\max}^2 2^{-2R} \quad (7.43)$$

- ◇ The output signal-to-noise ratio of a uniform quantizer is given by

$$(\text{SNR})_o = \frac{P}{\sigma_Q^2} = \left( \frac{3P}{m_{\max}^2} \right) 2^{2R} \quad (7.44)$$

- ◇ Eq. (7.44) shows that the output SNR of the quantizer increases exponentially with increasing of bits per sample.

# 7.8 The Quantization Process



## ◇ Example 7.2 : Sinusoidal Modulating Signal.

- ◇ Consider a full-load sinusoidal modulation signal of amplitude  $A_m$ , which utilizes all the representation level provided. The average signal power is

$$P = \frac{A_m^2}{2}$$

- ◇ The range of quantizer input is between  $-A_m$  and  $A_m$ .
- ◇ The quantization noise as

$$\sigma_Q^2 = \frac{1}{3} A_m^2 2^{-2R}$$

- ◇ Output SNR is

$$(\text{SNR})_o = \frac{A_m^2/2}{(A_m^2 2^{-2R})/3} = \frac{3}{2} (2^{2R}) \quad (7.45)$$

# 7.8 The Quantization Process



- ◇ Expressing the SNR in decibels, we get

$$10\log_{10}(\text{SNR})_o = 1.8 + 6R \quad (7.46)$$

- ◇ For various values of  $L$  and  $R$ , the corresponding values of SNR are as given in the table as follows.

<b>Number of Representation Levels, <math>L</math></b>	<b>Number of Bits/Sample, <math>R</math></b>	<b>Signal-to-Noise Ratio, (dB)</b>
32	5	31.8
64	6	37.8
128	7	43.8
256	8	49.8



# Chapter 7.9

## Pulse-Code Modulation

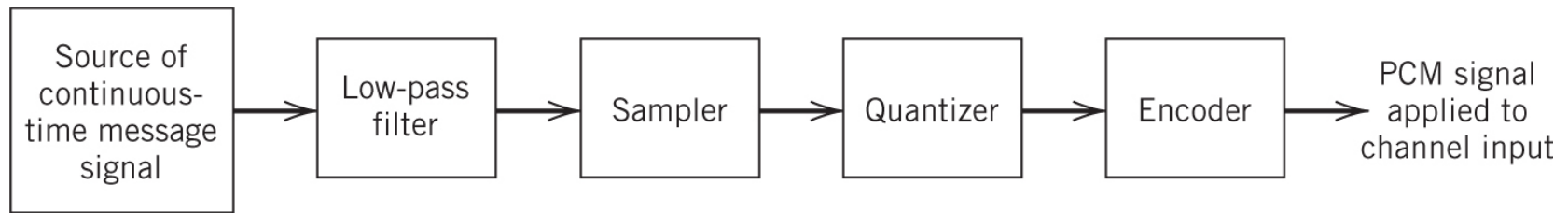


Wireless Information Transmission System Lab.  
Institute of Communications Engineering  
National Sun Yat-sen University

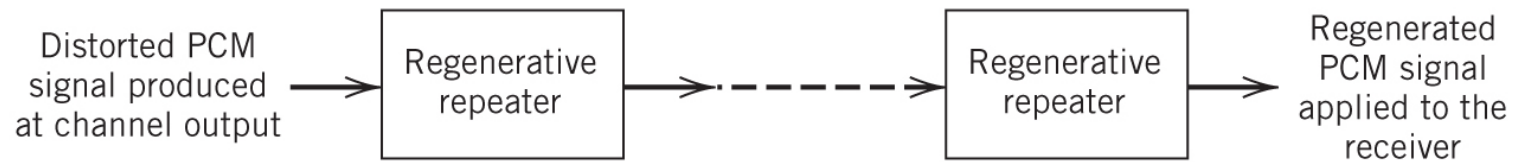
# 7.9 Pulse-Code Modulation



- ◇ In pulse-code modulation (PCM) a message signal is represented by a sequence of coded pulses, which is accomplished by representing the signal in discrete form in both time and amplitude.



(a) Transmitter



(b) Transmission path



(c) Receiver

# 7.9 Pulse-Code Modulation



- ◇ Sampling
  - ◇ The incoming message signal is sampled with a train of narrow rectangular pulses so as to closely approximate the instantaneous sampling process. Sampling rate must be greater than  $2W$ .
  - ◇ A pre-alias filter is used at the front end of the sampler in order to exclude frequencies greater than  $W$  before sampling.
  
- ◇ Quantization
  - ◇ The quantization process may follow a uniform law as described in the previous section.
    - ◇ Unacceptable signal-to-noise ratio for small signals.
    - ◇ Solution: Increasing quantization levels – price is too high.

# 7.9 Pulse-Code Modulation



- ◇ In certain applications, it is preferable to use a variable separation between the representation levels.
- ◇ The use of a nonuniform quantizer is equivalent to pass the baseband signal through a compressor and applying the compressed signal to a uniform quantizer.
- ◇ In order to restore the signal samples to their correct relative level, we must use a device in the receiver with a characteristic complementary to the compressor. Such a device is called an expander.
- ◇ The compression and expansion laws are exactly inverse so that, except for the effect of quantization, the expander output is equal to the compressor input.
- ◇ The combination of a compressor and an expander is called a componder.

# 7.9 Pulse-Code Modulation



- ◇ Two major types of compression law
  - ◇  $\mu$  - law (usually  $\mu = 255$ ; used in US, Canada, Japan)

$$|v| = \frac{\log(1 + \mu|m|)}{\log(1 + \mu)} \quad (7.47)$$

- ◇ A - law (usually  $A = 87.6$ ; used in Europe)

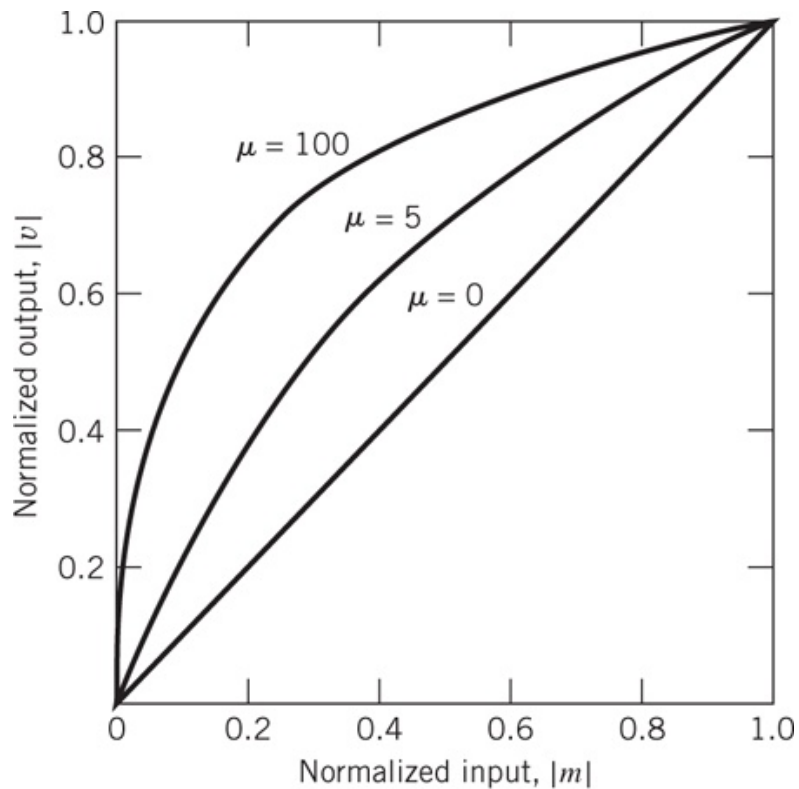
$$|v| = \begin{cases} \frac{A|m|}{1 + \log A}, & 0 \leq |m| \leq \frac{1}{A} \\ \frac{1 + \log(A|m|)}{1 + \log A}, & \frac{1}{A} \leq |m| \leq 1 \end{cases} \quad (7.48)$$

- ◇  $m$  and  $v$  are the normalized input and output voltages, respectively.
- ◇ The case of uniform quantization corresponds to  $\mu=0$  and  $A=1$ .

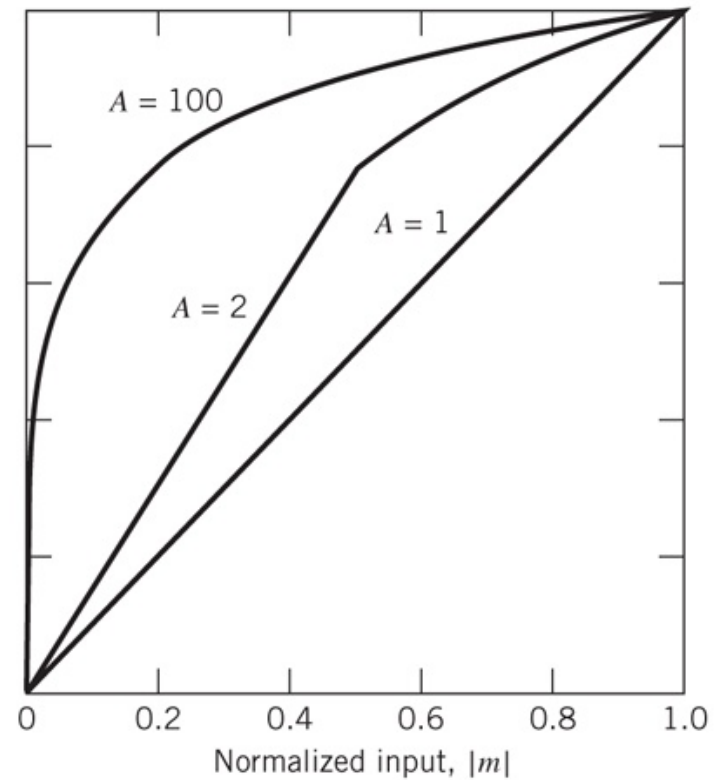
# 7.9 Pulse-Code Modulation



**$\mu$  - law**



**A - law**



# 7.9 Pulse-Code Modulation



## ◇ Encoding

- ◇ In combining the processes of sampling and quantizing, the specification of a continuous message (baseband) signal becomes limited to a discrete set of values, but not in the form best suited to transmission over a line or radio path.
- ◇ To exploit the advantages of sampling and quantizing for the purpose of making the transmitted signal more robust to noise, interference, and other channel degradations, we require the use of an encoding process to translate the discrete set of sample values to a more appropriate form of signal.
- ◇ Any plan for representing each of this discrete events is called a code.

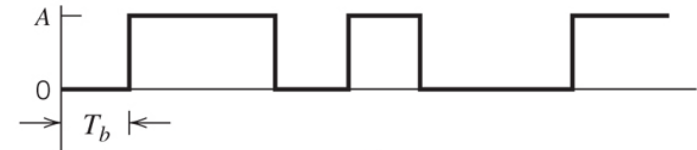
# 7.9 Pulse-Code Modulation



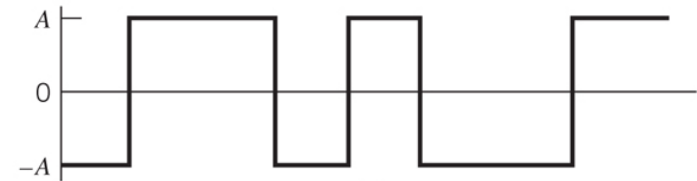
## Line Codes

- Unipolar Nonreturn-to-Zero (NRZ) signaling
- Polar Nonreturn-to-Zero (NRZ) signaling
- Unipolar Return-to-Zero (RZ) signaling
- Bipolar Return-to-Zero (BRZ) signaling
  - Alternate Mark Inversion (AMI)
- Split-Phase (Manchester Code)

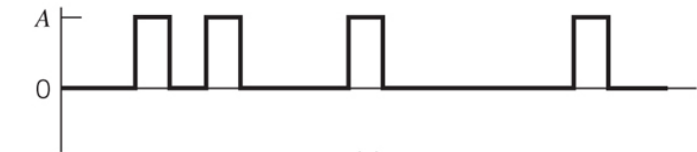
Binary data 0 1 1 0 1 0 0 1



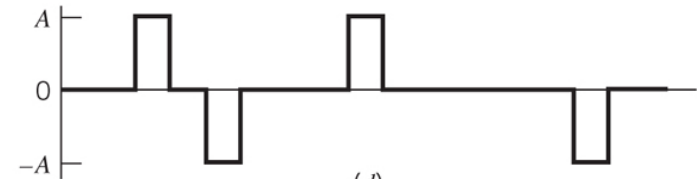
(a)



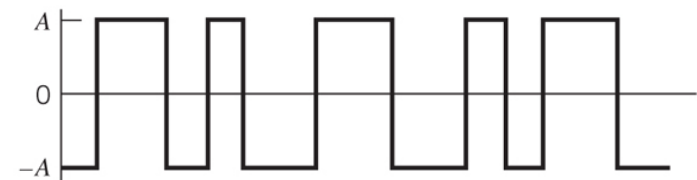
(b)



(c)



(d)



(e)

Time →



# 7.9 Pulse-Code Modulation



- ◇ Unipolar Nonreturn-to-Zero (NRZ) signaling
  - ◇ Symbol 1 is represented by transmitting a pulse of amplitude  $A$  for the duration of the symbol, and symbol 0 is represented by switching off the pulse.
  - ◇ This line code is also referred to as *on-off signaling*.
  - ◇ A disadvantage of on-off signaling is the waste of power due to the transmitted DC level.
  
- ◇ Polar Nonreturn-to-Zero (NRZ) signaling
  - ◇ Symbol 1 and 0 are represented by transmitting pulses of amplitudes  $+A$  and  $-A$ .
  - ◇ This line code is relatively easy to generate and is more power-efficient than its unipolar counterpart.

# 7.9 Pulse-Code Modulation



- ◇ Unipolar Return-to-Zero (RZ) signaling
  - ◇ Symbol 1 is represented by a rectangular pulse of amplitude  $A$  and half-symbol width, and symbol 0 is represented by transmitting no pulse.
  - ◇ An attractive feature is the presence of delta function at  $f = 0$ ,  $\pm 1/T_b$  in the power spectrum of the transmitted signal, which can be used for bit-timing recovery at the receiver.
  - ◇ It requires 3 dB more power than polar return-to-zero signaling for the same probability of symbol error.
  
- ◇ Bipolar Return-to-Zero (BRZ) signaling
  - ◇ This line code uses three amplitude levels. ( $0, \pm A$ )
  - ◇ No pulse is always used for symbol 0.

# 7.9 Pulse-Code Modulation



- ◇ Positive and negative pulses of equal amplitude ( $+A$  and  $-A$ ) are used alternately for symbol 1, with each pulse having a half-symbol width.
- ◇ The transmitted signal has no DC components.
- ◇ Also called alternate mark inversion (AMI) signaling.
- ◇ Split-Phase (Manchester Code)
  - ◇ Symbol 1 is represented by a positive pulse of amplitude  $A$  followed by a negative pulse of amplitude  $-A$ , with both pulses being a half-symbol wide.
  - ◇ For symbol 0, the polarities of these two pulses are reversed.
  - ◇ The Manchester code suppress the DC component and has relatively insignificant low-frequency components, regardless of the signal statistics.

# 7.9 Pulse-Code Modulation



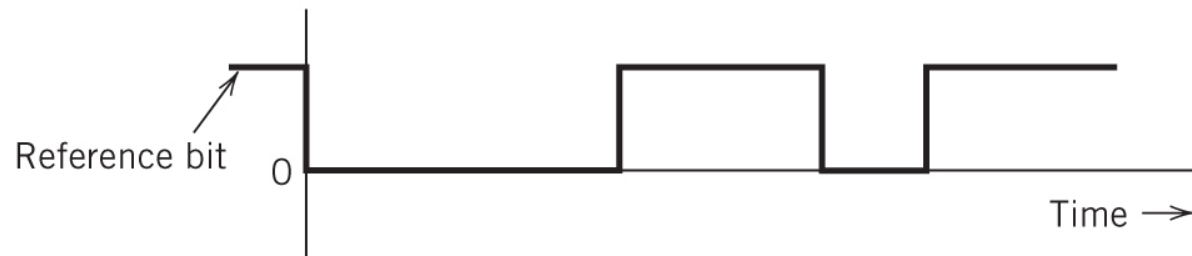
## ◇ Differential Encoding

- ◇ This method is used to encode information in terms of signal transitions.
- ◇ A transition is used to designate symbol 0 in the incoming binary data stream, while no transition is used to designate symbol 1.
- ◇ The waveform of the differentially encoded data assumes the use of unipolar nonreturn-to-zero signaling.
- ◇ The original binary information is recovered by comparing the polarity of adjacent binary symbols to establish whether or not a transition has occurred.
- ◇ Notice that differential encoding requires the use of a reference bit before initiating process.

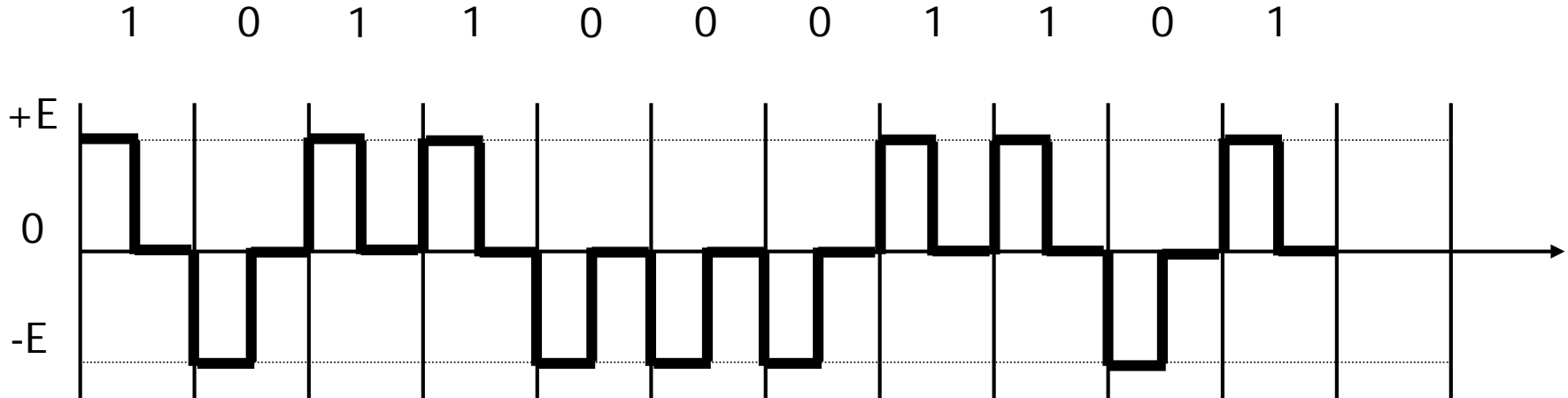
(a) Original binary data                      0    1    1    0    1    0    0    1

(b) Differentially encoded data            1    0    0    0    1    1    0    1    1

(c) Waveform

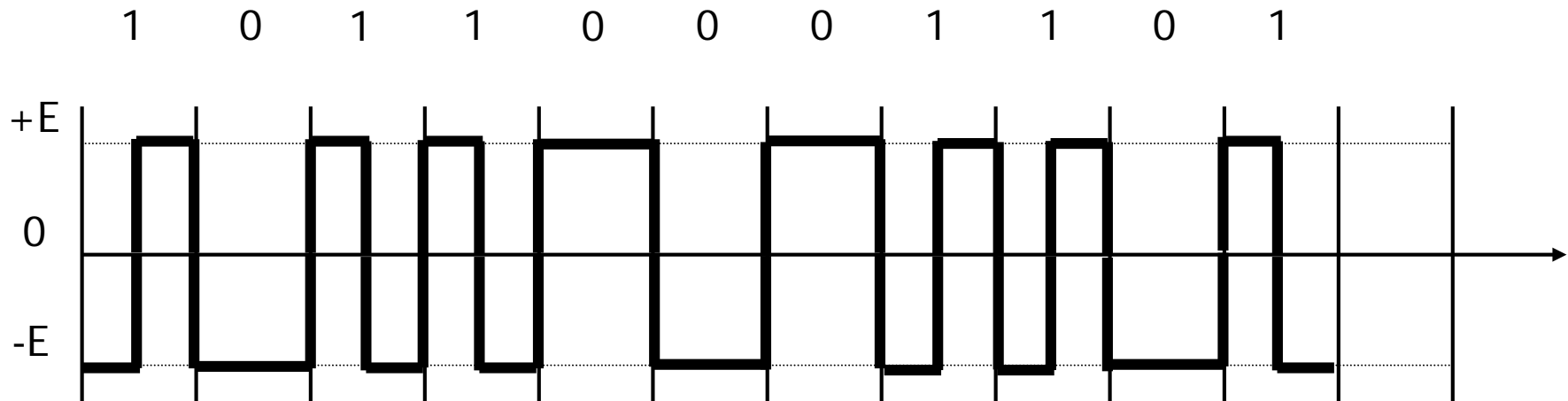


# 7.9 Pulse-Code Modulation



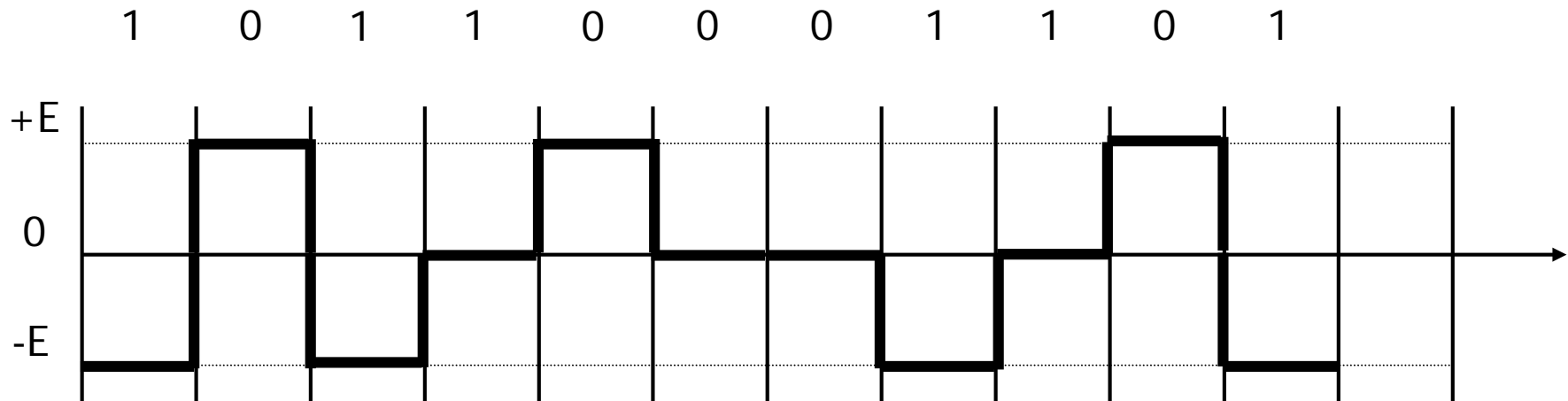
- ◇ Polar - RZ
  - ◇ “One” and “Zero” are represented by opposite level polar pulses that are one half-bit in width.

# 7.9 Pulse-Code Modulation



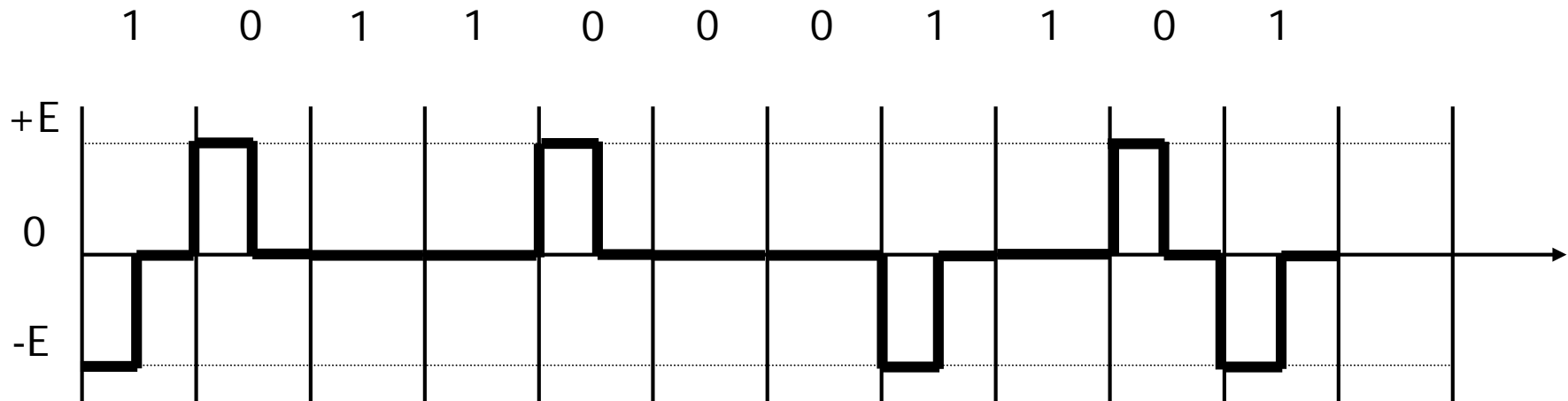
- ◇ Bi- $\phi$ -M ( Biphase Mark or Manchester 1)
  - ◇ A transition occurs at the beginning of every bit period.
  - ◇ “One” is represented by a second transition one half bit period later.
  - ◇ “Zero” is represented by no second transition.

# 7.9 Pulse-Code Modulation



- ◇ Dicode Non-Return-to-Zero
  - ◇ A “One” to “Zero” or “Zero” to “One” changes polarity.
  - ◇ Otherwise, a “Zero” is sent.

# 7.9 Pulse-Code Modulation

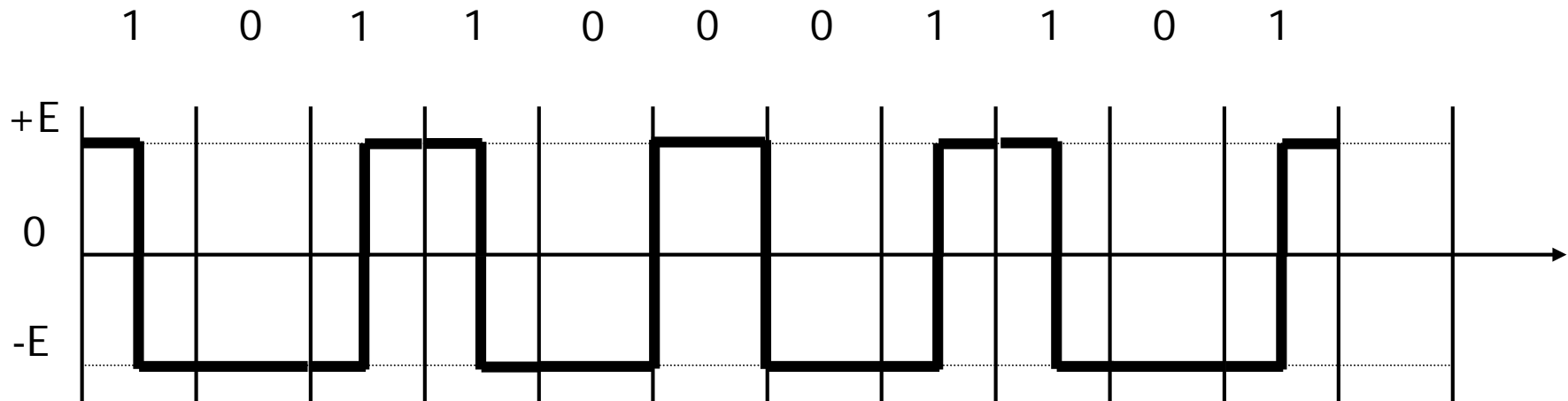


## ◇ Dicode Return-to-Zero

- ◇ A “One” to “Zero” or “Zero” to “One” transition produces a half duration polarity change.
- ◇ Otherwise, a “Zero” is sent.



# 7.9 Pulse-Code Modulation



- ◇ Dicode Non-Return-to-Zero
  - ◇ A “One” is represented by a transition at the midpoint of the bit interval.
  - ◇ A “Zero” is represented by a no transition unless it is followed by another zero. In this case, a transition is placed at the end of bit period of the first zero.

# 7.9 Pulse-Code Modulation



**TABLE 4.6 Encoding Table for 4B3T Line Code**

Binary Word	Ternary Word (Accumulated Disparity)		
	-	0	+
0000	- - -		+ + +
0001	- - 0		+ + 0
0010	- 0 -		+ 0 +
0011	0 - -		0 + +
0100	- - +		+ + -
0101	- + -		+ - +
0110	+ - -		- + +
0111	- 0 0		+ 0 0
1000	0 - 0		0 + 0
1001	0 0 -		0 0 +
1010		0 + -	
1011		0 - +	
1100		+ 0 -	
1101		- 0 +	
1110		+ - 0	
1111		- + 0	

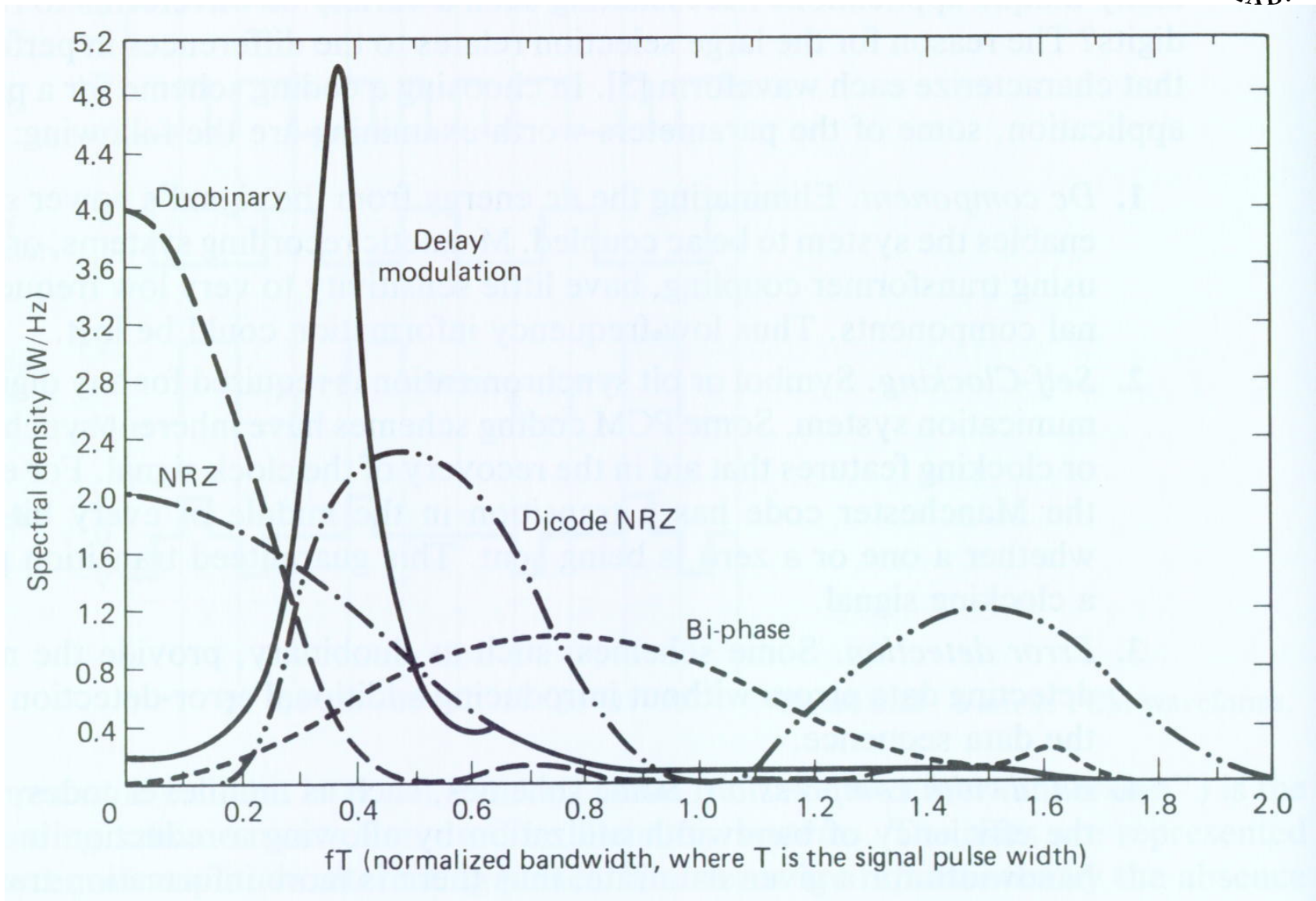
# 7.9 Pulse-Code Modulation



## ◇ 4B3T Line Code

- ◇ Ternary words in the middle column are balanced in their DC content.
- ◇ Code words from the first and third columns are selected alternately to maintain DC balance.
- ◇ If more positive pulses than negative pulses have been transmitted, column 1 is selected.
- ◇ Notice that the all-zeros code word is not used.

# Spectral Densities of Various PCM Waveforms



# 7.9 Pulse-Code Modulation



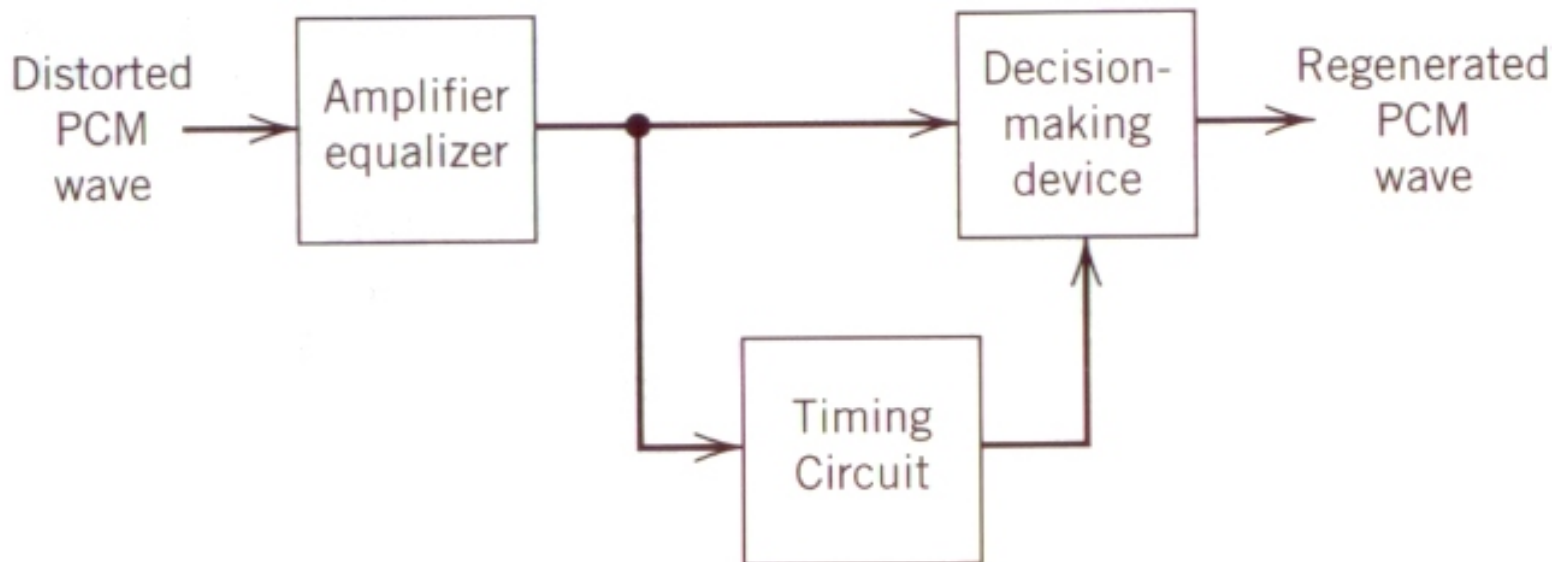
- ◇ Criteria for Selecting PCM Waveform
  - ◇ DC component: eliminating the dc energy from the signal's power spectrum.
  - ◇ Self-Clocking: Symbol or bit synchronization is required for any digital communication system.
  - ◇ Error detection: some schemes provide error detection without introducing additional error-detection bits.
  - ◇ Bandwidth compression: some schemes increase bandwidth utilization by allowing a reduction in required bandwidth for a given data rate.
  - ◇ Noise immunity.
  - ◇ Cost and complexity.

# 7.9 Pulse-Code Modulation



## ◇ Regeneration

- ◇ The most important feature of any digital system lies in the ability to control the effects of distortion and noise produced by transmitting a digital signal through a channel.
- ◇ This capability is accomplished by reconstructing the signal by means of a chain of regenerative repeaters, which perform three basic functions: equalization, timing, and decision making.



# 7.9 Pulse-Code Modulation



- ◇ Equalizer: shapes the received pulses so as to compensate for the effects of amplitude and phase distortions produced by the channel.
- ◇ Timing Circuitry: provides a periodic pulse train, derived from the received pulses, for sampling the equalized pulses at the instants of time where the signal-to-noise ratio is a maximum.
- ◇ Decision-making Device: the sample extracted is compared to a predetermined threshold.
- ◇ The regenerated signal may depart from the original signal:
  - ◇ The unavoidable presence of channel noise and interference causes the repeater to make wrong decisions occasionally, thereby introducing bit error in to regenerated signal.
  - ◇ If the spacing between received pulses deviates from its assigned value, a jitter is introduced into the regenerated pulse position, thereby causing distortion.



# 7.9 Pulse-Code Modulation



## ◇ Decoding

- ◇ The first operation in the receiver is to regenerate the received pulse one last time.
- ◇ These clean pulses are then regrouped into code words and decoded in to a quantized PAM signal.
- ◇ The decoding process involves generating a pulse the amplitude of which is the linear sum of all the pulses in the code word, with each pulse being weighted by its place value  $(2^0, 2^1, \dots, 2^{R-1})$ , where  $R$  is the number of bits per sample.

## ◇ Filtering

- ◇ The final operation in the receiver is to recover the message signal wave by passing the decoder output through a low-pass reconstruction filter whose cutoff frequency is equal to the message bandwidth  $W$ .



# Chapter 7.10

## Delta Modulation

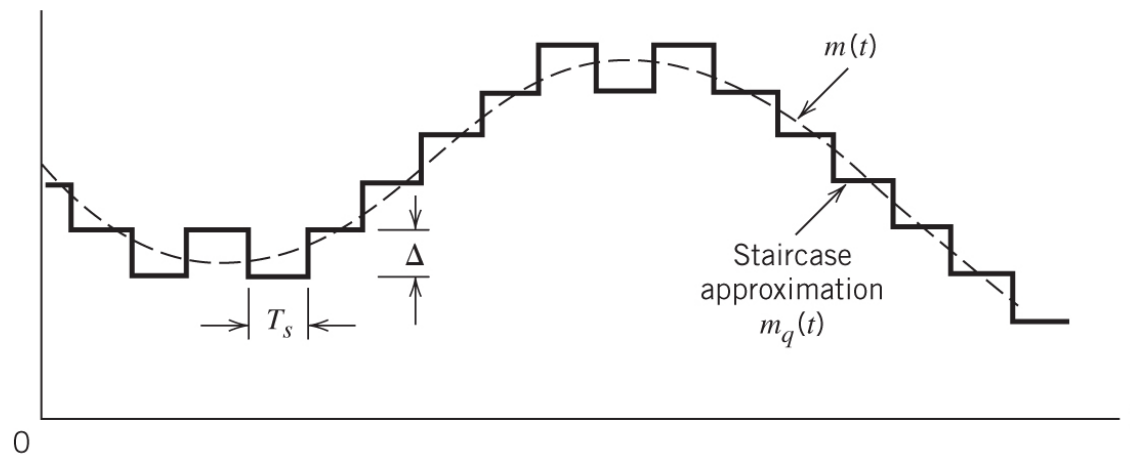


Wireless Information Transmission System Lab.  
Institute of Communications Engineering  
National Sun Yat-sen University

# 7.10 Delta Modulation



- ◇ In some applications, the increased bandwidth requirement of PCM is a major concern.
- ◇ In delta modulation (DM), an incoming message signal is oversampled (at a rate much higher than the Nyquist rate) to purposely increase the correlation between adjacent samples of the signal.



(a)

Binary  
sequence  
at modulator  
output

0 0 1 0 1 1 1 1 1 0 1 0 0 0 0 0 0

(b)

# 7.10 Delta Modulation

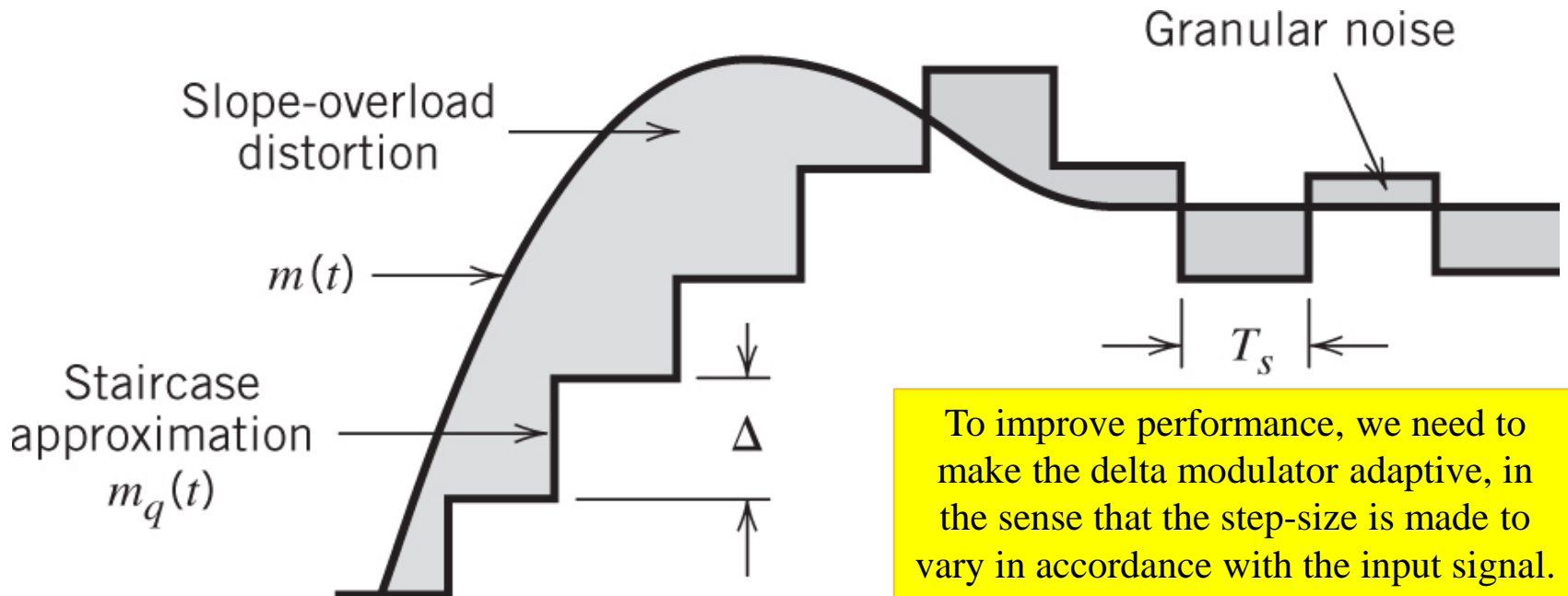


- ◇ The difference between the input and the approximation is quantized into only two levels, namely,  $\pm \Delta$ , corresponding to positive and negative differences, respectively.
- ◇ Provided that the signal does not change too rapidly from sample to sample, we find that the staircase approximation remains within  $\pm \Delta$  of the input signal.
- ◇ The delta modulator using a fixed step-size is often referred to as a linear delta modulator.
- ◇ The principle virtue of DM is its simplicity.
- ◇ DM is subject to two types of quantization error:
  - ◇ Slope Overload Distortion
  - ◇ Granular Noise

# 7.10 Delta Modulation



- ◇ Slope-overload distortion occurs when the  $\Delta$  is too small relative to the local slope of  $m(t)$ . In order for the sequence of samples to increase as fast as the input sequence, we require that 
$$\frac{\Delta}{T_s} \geq \max \left| \frac{dm(t)}{dt} \right|$$
- ◇ Granular noise occurs when the  $\Delta$  is too large relative to the local slope of  $m(t)$ .



To improve performance, we need to make the delta modulator adaptive, in the sense that the step-size is made to vary in accordance with the input signal.

# 7.10 Delta Modulation



- ◇ Delta-Sigma Modulation
  - ◇ A drawback of delta modulation is that transmission disturbances such as noise result in an accumulative error in the modulated signal.
  - ◇ This drawback can be overcome by integrating the message signal prior to delta modulation.
  - ◇ A DM scheme that incorporates integration at its input is called delta-sigma modulation or sigma-delta modulation.
- ◇ The reason for investing in delta modulation is its **reduced bandwidth requirements** compared to PCM.
  - ◇ For telephone applications, a typical PCM system may use an 8-kHz sampling rate with an 8-bit representation for an overall binary symbol rate of 64 kHz. Typical oversampling rates for delta modulation range from 16 to 32 kHz. Thus DM may provide a net bandwidth saving of 50 to 75 percent over PCM.